

SRC1200

SRC1200 ROUGH-TERRAIN CRANE
120 TONS LIFTING CAPACITY

Quality Changes the World

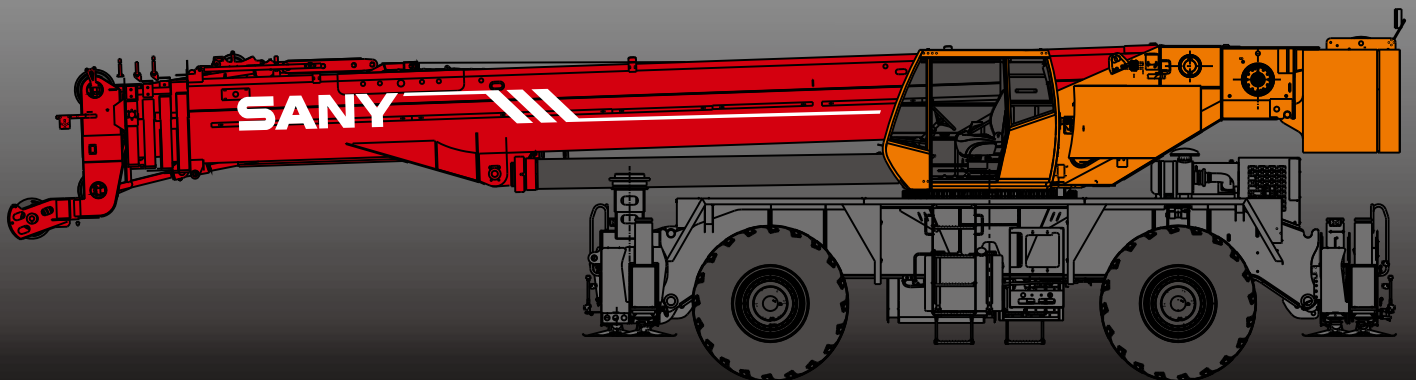

SANY

■ SANY Automobile Hoisting Machinery is one of the core business unit of Sany Heavy Industry, mainly engaged in the research and development of high end, mid to large tonnage crane series, including mobile crane, crawler crane, tower crane and loader crane. It has two industrial parks in Ningxiang and Huzhou, since entering the market, the products of Sany Automobile Hoisting Machinery have received worldwide recognition with advanced technology, lean manufacturing, high reliability and excellent service.





SANY ROUGH-TERRAIN CRANE

CONTENT

04	Icon
05	Selling Points
06	Introduction
09	Dimension
11	Technical Parameter
12	Operation Condition
13	Load Chart
23	Wheel Crane Family Map
24	Counterweight sketch Map



Cab



Carrier frame



Suspension system



Hydraulic system



Outriggers



Telescopic boom



Control system



Engine



Lattice jibs



Telescopic system



Transmission system



Superlift devices



Luffing system



Drive/Steer



Luffing lattice jib



Slewing



Axles



winch mechanism:



Counterweight



Tyres



Safety system



Brakes system



Hoist system



Electrical system



Excellent traveling capacity and high-performance chassis system

Four-wheel drive is applied with full hydraulic power steering system, and with four steering modes to provide good mobility. Trafficability and comfortableness of the complex road condition is improved thanks to its Min. turning radius of less than 9.7m.

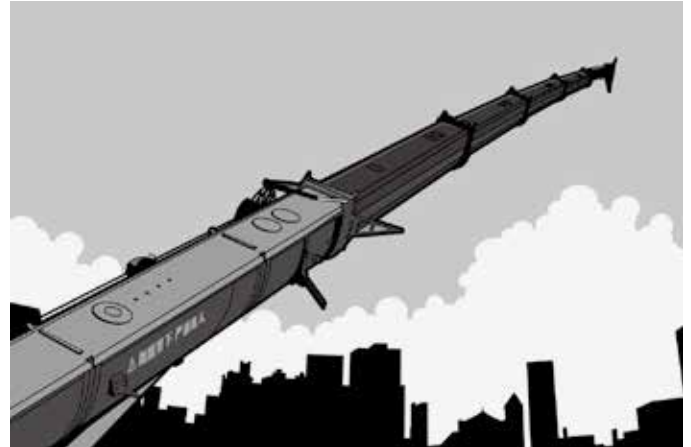

Ultra long and super strong boom system

Five-section boom with high strength steel structure and optimized U-shaped section, reducing weight and improving safety significantly. Jib mounting angles are 0°, 20°, and 40° which ensure fast and convenient change-over between different operating conditions so as to improve working efficiency of the machine.



Highly effective and original Electric control hydraulic system

The hydraulic system is equipped with the pump of load feedback and constant power control and electric proportion multitandem valve providing strong lifting capacity and good micro-mobility. Unique slewing buffer design guarantees smooth braking operation.



Safe and reliable control system

Self-developed controller SYMC specially for engineering machinery is configured. The application of CAN-bus fully digital network control technology ensures stable control signal, simple harness and high reliability. It can feedback the data information and monitor the working condition of whole crane in real-time. Load moment limiter configuring with comprehensive intelligent protection system is adopted with precision within 10%. The adoption of comprehensive logic and interlock control system ensures more safe and reliable operation.

Introduction

 Cab

- The self-made cab adopts ergonomic design with sliding door, safety glass, anti-corrosion steel, soft interior decoration, large interior space, panoramic sunroof and adjustable seats, air conditioner and electric window wiper etc. to provide easier and more comfortable operation. Meticulously designed industrial style and novel appearance are applied for cab. Load moment limiter display is configured to achieve the combination of main console and operating display system, making all operating condition data of lifting operation clear at a glance.
- The cab is adjustable up to 20° through the cylinder which provides convenient and comfortable operation in long boom condition.

 Hydraulic system

- High-quality key hydraulic components such as main pump, main valve, winch motor, and balancing valves etc. are adopted to achieve stable and reliable operation of the hydraulic system.
- Load sensitive variable piston pump is adopted to achieve high-precision flow control and reduce the energy loss greatly.
- The electric proportion valve is adopted and it is with the function of flow compensation, load feedback which could achieve the single/multi action/combination easily under variable working conditions.
- Winch adopts electronically controlled variable motor, to ensure high operation efficiency. Max. single line speeds of main and auxiliary winches is up to 140m/min;
- Slewing system is equipped with the integrated slewing buffer valve, with free slipping function, to ensure more stable starting and control of the slewing operation and excellent micro-mobility.
- Hydraulic oil tank capacity: 1220L.

 Control system

- Electric control system is equipped with global well-known brand joystick and connected by the CAN-bus which is excellent in control, stability and is convenient for maintenance.
- CAN-bus instrument: CAN-bus instrument with a combined intelligent control electrical system is used for easy reading of the traveling parameters at any time. Engine fault warning function enables convenient and fast maintenance.
- With full security protection system, main and auxiliary winches are equipped with over-roll out limiter and height limiters to prevent over-rolling out and over-hoisting of steel rope, including tip-over and limit angle protection.
- Load moment limiter: The adoption of highly intelligent load moment limiter system can comprehensively protect lifting operation, ensuring accurate, stable and comfort operation.
- Remote controller is adopted to provide flexible and safe operation.

 Telescopic system

- Five-section boom is applied that basic boom is 13m, fully-extended boom is 49m, jib is 18m and lifting height of fully-extended boom is 51.7m and max. lifting height is 69.6m including jib. It is made of fine grain high-strength steel, with U-shaped cross section and with telescopic operation controlled independent by double cylinder rope.

 Luffing system

- Dead-weight luffing provides more stable luffing operation at low energy loss. Dual-action single piston hydraulic pressure cylinder with safety valve is adopted.
- Luffing angle range is $-2^{\circ} \sim 78^{\circ}$.

Introduction



Slewing system

- 360° rotation can be achieved, with Max. slewing speed of 1.78r/min. Electric controlled proportional speed adjustment is applied, providing stable and reliable operation of the system. Unique slewing buffer design ensures more stable braking operation.



Counterweight

- There is one 16500kg self-assembly flexible counterweight. It is convenient for disassembly and transportation.



Safety system

- Load moment limiter: Load moment limiter calculation system based on lifting load mechanical model is established using an analytical mechanics method, with rated lifting accuracy up to 0-10% through on-line non-load calibration, providing full protection to lifting operation. In case of overload operation, system will automatically issue an alarm to provide safety protection for manipulation.
- Balance valve, overflow valve, and two-way hydraulic lock etc. components are configured for hydraulic system, thus achieving stable and reliable operation of the hydraulic system.
- Main and auxiliary winches are equipped with over roll-out limiter, to prevent over rolling-out of wire rope.
- Boom and jib ends are equipped with height limiters respectively to prevent over-hoisting of wire rope.
- Boom head is equipped with anemometer to monitor if the wind speed exceeds the operation requirement or not.



Hoist system

- The adoption of pump and motor double variable speed control ensures high efficiency and excellent energy saving functionality. With perfect combination of winch balance valve and unique anti-slip technology, heavy load can lift and lower smoothly. Closed winch brake and winch balance valve effectively prevent imbalance of the hook. High strength, anti-swirl steel wire is equipped for high-precision hoisting positioning.
- One 780kg main hook and one 275kg auxiliary hook are standard configuration and one 1538kg large hook is optional. Main and auxiliary hook steel rope diameters are 22mm, the rope length is 280m and 190m respectively.



Carrier frame

- Carrier frame is welded with high-strength steel plate, featuring high lifting capacity.

Introduction

 **Outriggers**

- Both front and rear outriggers could be disassembled by the crane itself for transportation. H-type outrigger structure and 4-point support is adopted, with Max. span up to 8.52m×8.54m. Fine grain high strength steel material is adopted and dual-direction hydraulic lock is used for the protection of vertical span cylinder.

 **Engine**

- Type: Inline six-cylinder, water cooled, supercharged and inter-cooling diesel engine
- Rated power: 242kw/2100r/min
- Environment-protection: Emission complies with Stage 3A standard
- Capacity of fuel tank: 350L

 **Transmission system**

- Gearbox: Automatic gearbox with six gears. The speed ratio range is large which meets the requirements of low gradeability speed and high traveling speed.
- Transmission shaft: With optimized arrangement of the transmission shaft, the transmission is stable and reliable.

 **Drive/Steer**

- 4×4 drive way is adopted, full hydraulic power steering is applied, having front wheel steering, rear wheel steering, four-wheel steering and crab traveling modes.

 **Axles**

- Both front and rear axles are steering and driving axle.

 **Tyres**

- 4*—875/65R29 ★★★ 218A2 TL ETADT

 **Brakes system**

- Double-circuit braking system is adopted, if one circuit fails, the other circuit can ensure normal operation, thus improving the safety and reliability of brake system.
- Traveling brake: all wheels are equipped with disc brakes.
- Parking brake is disc brakes equipped on the front axle import flange.

 **Electrical system**

- With 2*12V maintenance-free battery and mechanical power main switch, power of the whole machine can be cut off manually.

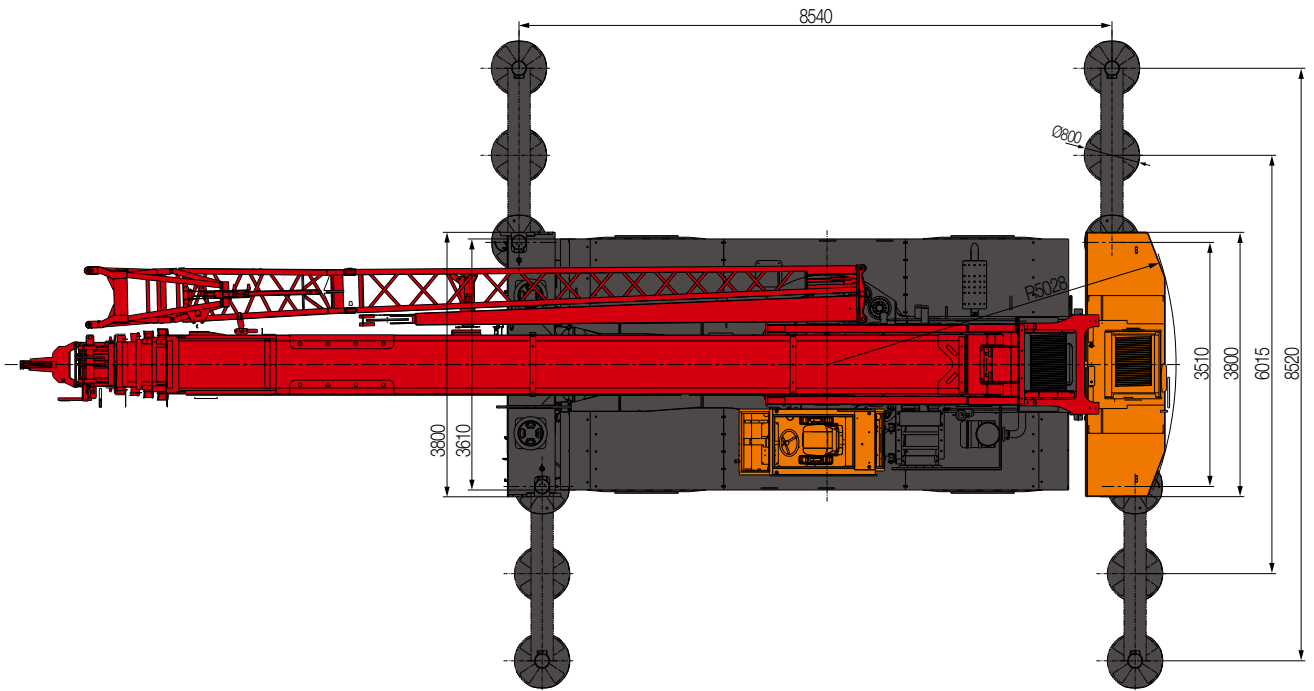
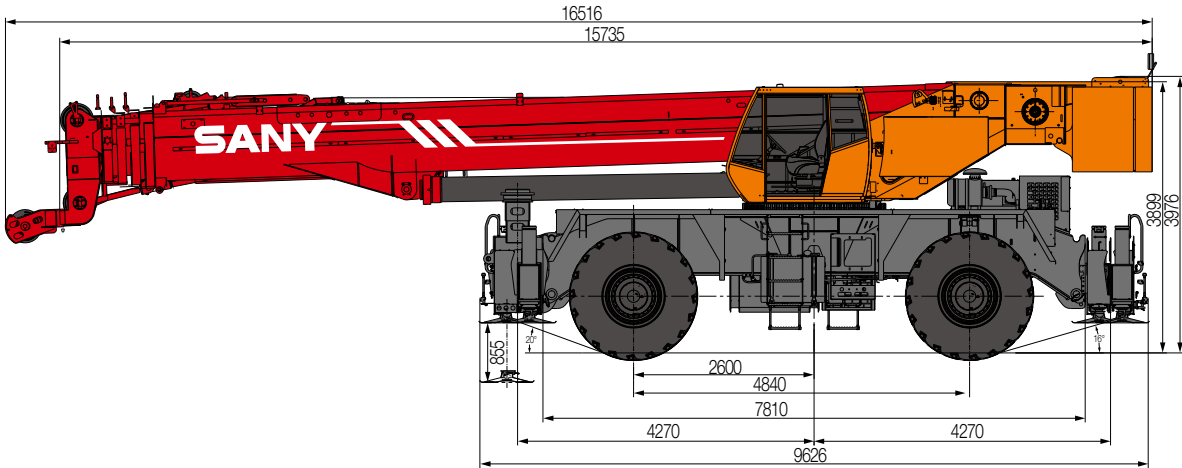

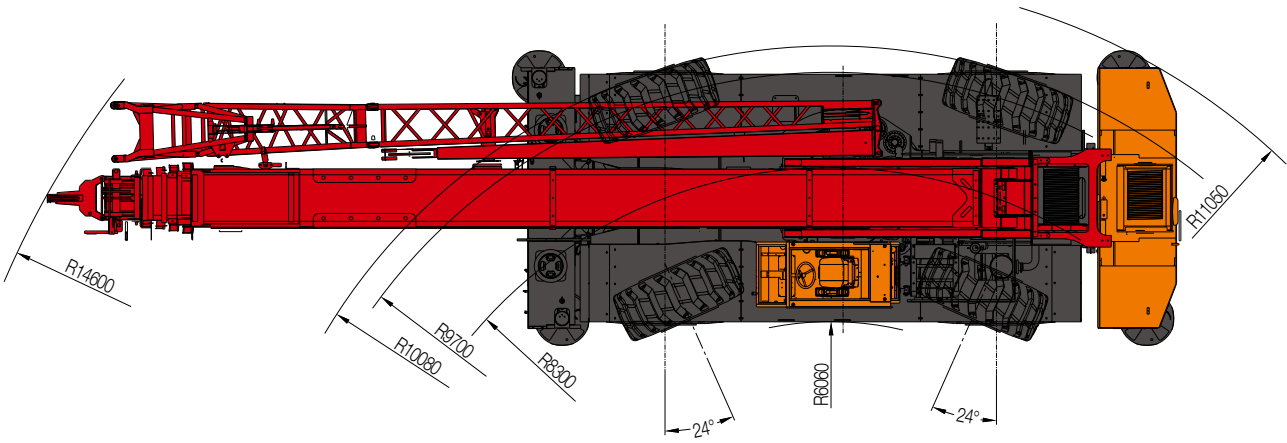
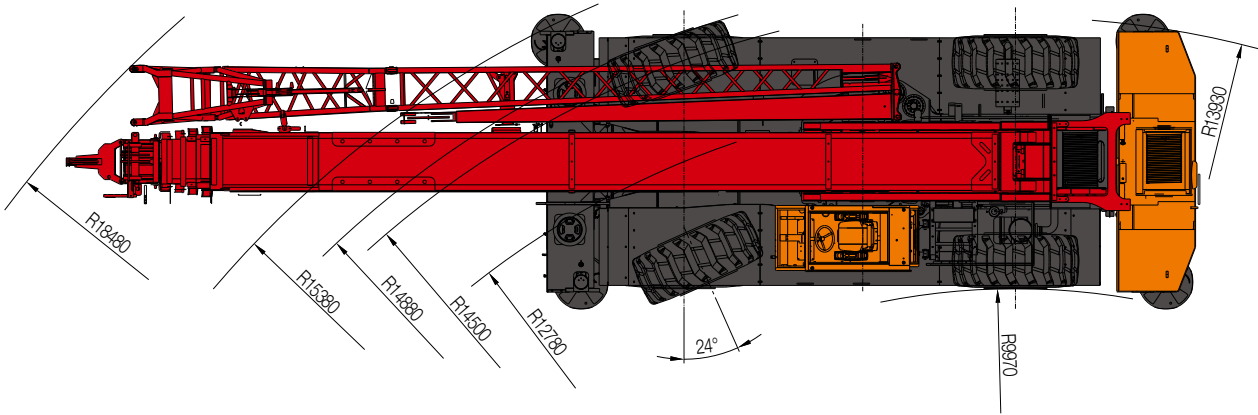

Type	Item	Parameter		
Capacity	Max. lifting capacity	120t		
Dimensions	Overall length	15735 mm		
	Overall width	3800 mm		
	Overall height	3976 mm		
	Axle distance	4840 mm		
Weight	Overall weight	76612 kg		
	Axle load	Front axle load	37797 kg	
		Rear axle load	38815 kg	
Engine	Rated power	242 kW/ 2100 rpm		
	Rated torque	1385 N.m/ 1500 rpm		
Traveling	Max.traveling speed	26 km/h		
	Turning radius	Min.turning radius	14.5/9.7 m	
	Wheel formula		4× 4	
	Min.ground clearance		510 mm	
	Approach angle		20 °	
	Departure angle		16 °	
	Max.gradeability		73.5%	
	Fuel consumption per 100km		≤ 165 L	
Main Performance Data	Temperature range		- 20 ° ~ + 46 °	
	Min.rated range		3.05 m	
	Tail slewing radius of swingtable		5.028 m	
	Boom section		5	
	Boom shape		U-shaped	
	Max.lifting moment	Base boom		3658kN·m
		Full-extend boom		1900kN·m
		Full-extend boom+jib		1492 kN·m
	Boom length	Base boom		13 m
		Full-extend boom		49 m
		Full-extend boom+jib		67 m
Outrigger span (Longitudinal×Transversal)		8.54 × 8.52 m		
Jib offset		0 °, 20 °, 40 °		
Working speed	Max.single rope lifting speed of main winch (no load)		140 m/min	
	Max.single rope lifting speed of auxiliary winch (no load)		140 m/min	
	Full extension/retraction time of boom		135/175 s	
	Full lifting/descending time of boom		67/110 s	
	Slewing speed		1.78 r/min	
Air condition	Superstructure / Chassis		Cooling/Heating & Cooling	

SRC1200 Working Ranges

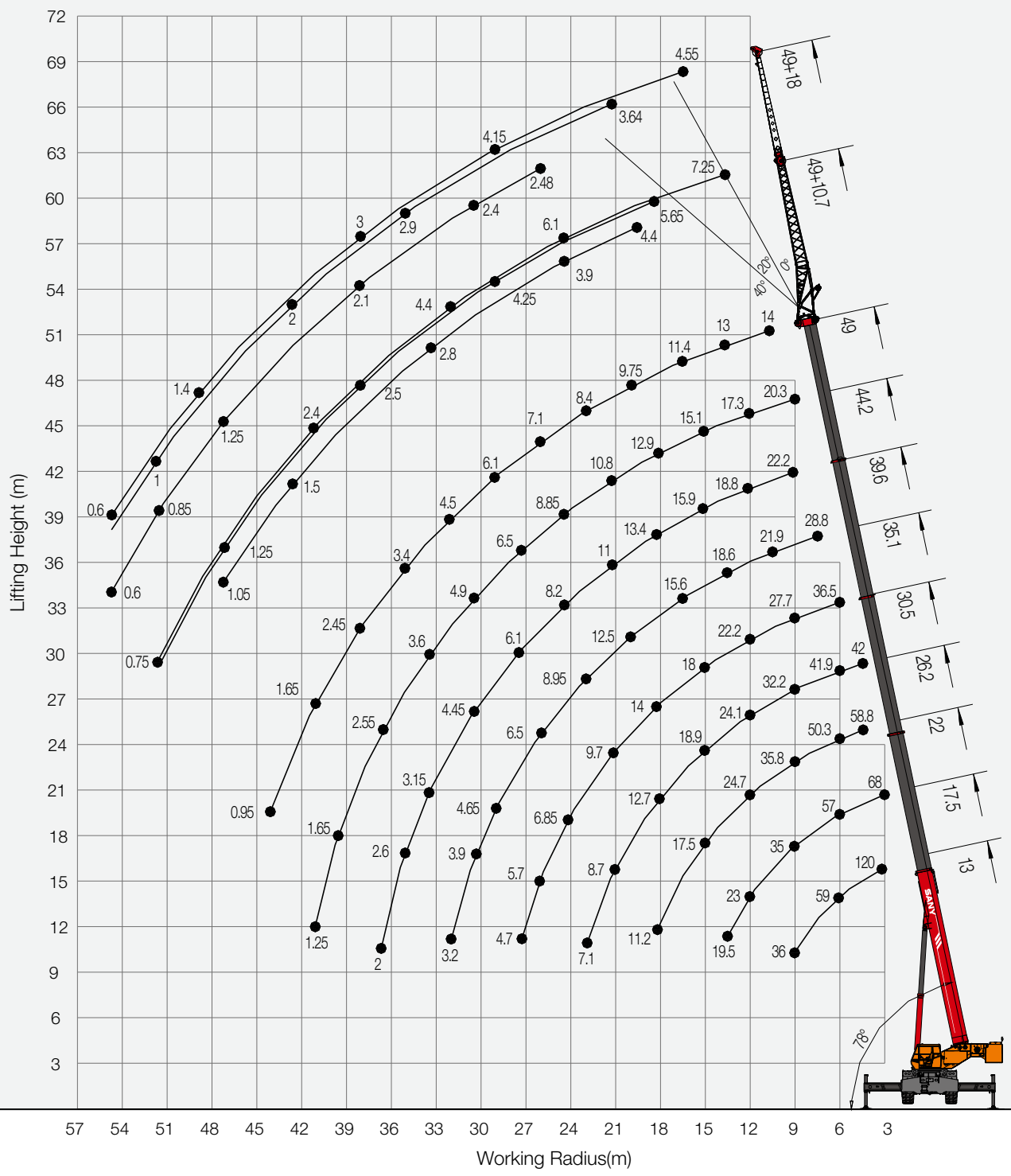

Prerequisites:

- ① Fully-extended boom. Boom length is from 13m to 49m
- ② Outrigger span is 8.52×8.54m
- ③ 360° rotation is applied
- ④ Counterweight weight is 16.5t

Working Range(m)	Main Boom (m)									Working Range(m)
	13.0	17.5	22.0	26.2	30.5	35.1	39.6	44.2	49.0	
3.05	120000	68000								3.05
3.66	102060	68000	58800							3.66
4.57	80000	67500	58800	42000						4.57
6.10	59000	57000	50300	41900	36500					6.10
7.62	45000	44000	43800	37700	32400	28840				7.62
9.14	36000	35000	35850	32200	27700	24850	22200	20300		9.14
10.67		28300	29500	28000	24400	21900	20300	18800	14000	10.67
12.19		23000	24700	24100	22200	20200	18800	17300	13500	12.19
13.72		19500	21000	21300	20000	18600	17200	16100	13000	13.72
15.24			17500	18900	18000	17000	15900	15100	12300	15.24
16.76			14000	16200	15800	15600	14700	14000	11450	16.76
18.29			11250	12750	14000	14000	13400	12900	10600	18.29
19.81				10500	12000	12550	12200	11800	9750	19.81
21.34				8700	9700	11000	11000	10800	9000	21.34
22.86				7150	8150	8950	9950	9800	8400	22.86
24.38					6850	7650	8200	8850	7800	24.38
25.91					5700	6500	7050	7500	7150	25.91
27.43					4700	5500	6100	6500	6700	27.43
28.96						4650	5200	5650	6150	28.96
30.48							3900	4450	4900	30.48
32.00							3200	3750	4200	32.00
33.53								3150	3600	33.53
35.05								2600	3050	35.05
36.58								2050	2550	36.58
38.10									2050	38.10
39.62									1650	39.62
41.15									1250	41.15
42.67										42.67
44.20										44.20
Telescopic Mode	I,II	I	I	I	I	I	I	I	I,II	Telescopic Mode
No. of line	16	10	8	6	6	4	4	4	3	No. of line
Cylinder 1	0%	50%	100%	100%	100%	100%	100%	100%	100%	Cylinder 1
Cylinder 2	0%	0%	0%	16%	31%	49%	65%	82%	100%	Cylinder 2
Min. elevation angle without load	/	/	/	/	/	/	/	/	15°	Min. elevation angle without load
0°elevation	16500	9300	4950	3480	2350	1480	820	260	/	0°elevation

SRC1200 ROUGH-TERRAIN CRANE
LOAD CHART
Prerequisites:

- ① Fully-extended boom. Boom length is from 13m to 49m
- ② Outrigger span is 8.52×8.54m
- ③ 360° rotation is applied
- ④ Counterweight weight is 16.5t

Working Range(m)	Main Boom (m)									Working Range(m)
	13.0	17.5	22.0	26.2	30.5	35.1	39.6	44.2	49.0	
3.05	120000	41900								3.05
3.66	102060	38650	36450							3.66
4.57	80000	36800	34050	28800						4.57
6.10	59000	33650	30200	25450	22150					6.10
7.62	45000	31800	27450	22800	19150	19500				7.62
9.14	36000	28100	25350	20850	16950	17350	14100	14000		9.14
10.67		24650	22100	18000	14850	15600	12500	12000	14000	10.67
12.19		21150	20250	15900	13450	14000	11150	10500	13500	12.19
13.72		15500	18050	14250	12100	12600	10000	9350	13000	13.72
15.24			16250	12850	11050	11400	9050	8450	12300	15.24
16.76			13800	11850	10050	10400	8300	7700	11450	16.76
18.29			10700	10900	9250	9600	7650	7150	10600	18.29
19.81				10150	8600	8850	7050	6650	9750	19.81
21.34				9450	8050	8350	6600	6150	9000	21.34
22.86				6350	7450	7750	6100	5750	8400	22.86
24.38					7000	7150	5700	5400	7800	24.38
25.91					6600	6700	5350	5100	7150	25.91
27.43					5800	6250	5000	4800	6700	27.43
28.96						5900	4700	4500	6150	28.96
30.48						5550	4450	4250	5600	30.48
32.00						5050	4200	4050	4550	32.00
33.53							4000	3850	3950	33.53
35.05							3800	3700	3400	35.05
36.58							3500	3500	2900	36.58
38.10								3350	2450	38.10
39.62								2550	2000	39.62
41.15								2150	1650	41.15
42.67									1250	42.67
44.20									950	44.20
Telescopic Mode	I,II	II	II	II	II	II	II	II	I,II	Telescopic Mode
No. of line	16	10	8	6	6	4	4	4	3	No. of line
Cylinder 1	0%	0%	0%	0%	0%	0%	0%	47%	100%	Cylinder 1
Cylinder 2	0%	17%	33%	49%	65%	82%	99%	100%	100%	Cylinder 2
Min. elevation angle without load	/	/	/	/	/	/	/	/	15°	Min. elevation angle without load
0°elevation	16500	11150	8000	6030	4550	3400	2500	1080	/	0°elevation

Prerequisites:

- ① Fully-extended boom. Boom length is from 13m to 49m
- ② Outrigger span is 6.015x8.54m
- ③ 360° rotation is applied
- ④ Counterweight weight is 16.5t

Working Range(m)	Main Boom (m)									Working Range(m)
	13.0	17.5	22.0	26.2	30.5	35.1	39.6	44.2	49.0	
3.05	108000	68000								3.05
3.66	96500	68000	58800							3.66
4.57	80000	67500	58800	42000						4.57
6.10	59000	57000	50300	41900	36500					6.10
7.62	41150	40650	40300	37700	32400	28840				7.62
9.14	28350	27950	27650	29250	27700	24850	22200	20300		9.14
10.67		20300	20050	21550	22600	21900	20300	18800	14000	10.67
12.19		15200	14950	16350	17400	18200	18800	17300	13500	12.19
13.72		11450	11300	12650	13650	14450	15050	16100	13000	13.72
15.24			8550	9900	10850	11600	12200	12650	12300	15.24
16.76			6350	7700	8650	9400	10000	10450	11450	16.76
18.29			4600	5950	6900	7650	8200	8650	9000	18.29
19.81				4550	5450	6200	6750	7200	7550	19.81
21.34				3300	4250	5000	5550	5950	6350	21.34
22.86				2300	3250	3950	4500	4950	5300	22.86
24.38					2350	3100	3600	4050	4400	24.38
25.91					1600	2350	2850	3300	3650	25.91
27.43					900	1650	2200	2600	2950	27.43
28.96						1050	1600	2000	2350	28.96
30.48							1050	1500	1850	30.48
32.00								1000	1350	32.00
33.53									900	33.53
Telescopic Mode	I,II	I	I	I	I	I	I	I	I,II	Telescopic Mode
No. of line	16	10	8	6	6	4	4	4	3	No. of line
Cylinder 1	0%	50%	100%	100%	100%	100%	100%	100%	100%	Cylinder 1
Cylinder 2	0%	0%	0%	16%	31%	49%	65%	82%	100%	Cylinder 2
Min. elevation angle without load	/	/	/	/	14°	28°	36°	41°	46°	Min. elevation angle without load
0°elevation	16500	9300	3200	1600	/	/	/	/	/	0°elevation

SRC1200 ROUGH-TERRAIN CRANE
LOAD CHART
Prerequisites:

- ① Fully-extended boom. Boom length is from 13m to 49m
- ② Outrigger span is 6.015x8.54m
- ③ 360° rotation is applied
- ④ Counterweight weight is 16.5t

Working Range(m)	Main Boom (m)									Working Range(m)
	13.0	17.5	22.0	26.2	30.5	35.1	39.6	44.2	49.0	
3.05	108000	41900								3.05
3.66	96500	38650	36450							3.66
4.57	80000	36800	34050	28800						4.57
6.10	59000	33650	30200	25450	22150					6.10
7.62	41150	31800	27450	22800	19150	19500				7.62
9.14	28350	28100	25350	20850	16950	17350	14100	14000		9.14
10.67		23000	22100	18000	14850	15600	12500	12000	14000	10.67
12.19		17750	19000	15900	13450	14000	11150	10500	13500	12.19
13.72		13950	15200	14250	12100	12600	10000	9350	13000	13.72
15.24			12350	12850	11050	11400	9050	8450	12300	15.24
16.76			10150	10850	10050	10400	8300	7700	11450	16.76
18.29			8300	9050	9250	9600	7650	7150	9000	18.29
19.81				7550	8600	8850	7050	6650	7550	19.81
21.34				6350	6850	7200	6600	6150	6350	21.34
22.86				5300	5800	6200	6100	5750	5300	22.86
24.38					4900	5300	5700	5400	4400	24.38
25.91					4100	4500	4800	4200	3650	25.91
27.43					3400	3800	4100	3500	2950	27.43
28.96						3200	3500	2900	2350	28.96
30.48						2650	2950	2400	1850	30.48
32.00						2150	2450	1900	1350	32.00
33.53							2050	1450	900	33.53
35.05							1650			35.05
36.58							1250			36.58
Telescopic Mode	I,II	II	II	II	II	II	II	II	I,II	Telescopic Mode
No. of line	16	10	8	6	6	4	4	4	3	No. of line
Cylinder 1	0	0%	0%	0%	0%	0%	0%	47%	100%	Cylinder 1
Cylinder 2	0	17%	33%	49%	65%	82%	99%	100%	100%	Cylinder 2
Min. elevation angle without load	/	/	/	/	/	/	/	36°	46°	Min. elevation angle without load
0°elevation	16500	11150	6900	4650	3100	1900	1100	/	/	0°elevation

Prerequisites:

- ① Fully-extended boom. Boom length is from 13m to 49m
- ② Outrigger span is 3.51×8.54m
- ③ 360° rotation is applied
- ④ Counterweight weight is 16.5t

Working Range(m)	Main Boom (m)									Working Range(m)
	13.0	17.5	22.0	26.2	30.5	35.1	39.6	44.2	49.0	
3.05	88600	68000								3.05
3.66	76500	68000	58800							3.66
4.57	50000	49350	48950	42000						4.57
6.10	29000	28450	28150	29700	30800					6.10
7.62	18850	18400	18100	19500	20550	21350				7.62
9.14	12850	12500	12200	13550	14500	15300	15850	16350		9.14
10.67		8550	8300	9600	10500	11250	11800	12300	12650	10.67
12.19		5750	5550	6800	7700	8400	8950	9400	9750	12.19
13.72		3650	3450	4700	5600	6300	6850	7250	7600	13.72
15.24			1850	3050	3950	4650	5200	5600	5950	15.24
16.76			550	1750	2650	3350	3850	4250	4600	16.76
18.29				700	1600	2250	2800	3200	3550	18.29
19.81					700	1400	1900	2300	2650	19.81
21.34						600	1150	1550	1850	21.34
22.86								900	1200	22.86
24.38									650	24.38
Telescopic Mode	I,II	I	I	I	I	I	I	I	I,II	Telescopic Mode
No. of line	12	10	8	6	6	4	4	4	3	No. of line
Cylinder 1	0%	50%	100%	100%	100%	100%	100%	100%	100%	Cylinder 1
Cylinder 2	0%	0%	0%	16%	31%	49%	65%	82%	100%	Cylinder 2
Max. elevation angle without load	76°	/	/	/	/	/	/	/	/	Max. elevation angle without load
Min. elevation angle without load	/	/	32°	39°	45°	49°	55°	58°	60°	Min. elevation angle without load
0°elevation	9050	2200	/	/	/	/	/	/	/	0°elevation

SRC1200 ROUGH-TERRAIN CRANE
LOAD CHART
Prerequisites:

- ① Fully-extended boom. Boom length is from 13m to 49m
- ② Outrigger span is 3.51×8.54m
- ③ 360° rotation is applied
- ④ Counterweight weight is 16.5t

Working Range(m)	Main Boom (m)									Working Range(m)
	13.0	17.5	22.0	26.2	30.5	35.1	39.6	44.2	49.0	
3.05	88600	41900								3.05
3.66	76500	38650	36450							3.66
4.57	50000	36800	34050	28800						4.57
6.10	29000	33650	30200	25450	22150					6.10
7.62	18850	21000	22200	22800	19150	19500				7.62
9.14	12850	14950	16050	16750	16950	17350	14100	14000		9.14
10.67		10950	12050	12700	13200	13600	12500	12000	12650	10.67
12.19		8050	9200	9850	10300	10700	11150	10500	9750	12.19
13.72		5900	7050	7700	8150	8500	8800	8200	7600	13.72
15.24			5350	6000	6500	6850	7100	6550	5950	15.24
16.76			4050	4700	5150	5500	5800	5200	4600	16.76
18.29			2950	3600	4050	4400	4700	4100	3550	18.29
19.81				2700	3150	3500	3750	3200	2650	19.81
21.34				1900	2400	2750	3000	2450	1850	21.34
22.86				1250	1700	2100	2350	1750	1200	22.86
24.38					1150	1500	1750	1200	650	24.38
25.91						1000	1250			25.91
27.43							850			27.43
Telescopic Mode	I,II	II	II	II	II	II	II	II	I,II	Telescopic Mode
No. of line	12	10	8	6	6	4	4	4	3	No. of line
Cylinder 1	0	0%	0%	0%	0%	0%	0%	47%	100%	Cylinder 1
Cylinder 2	0	17%	33%	49%	65%	82%	99%	100%	100%	Cylinder 2
Max. elevation angle without load	76°	/	/	/	/	/	/	/	/	Max. elevation angle without load
Min. elevation angle without load	/	/	/	/	30°	38°	43°	55°	60°	Min. elevation angle without load
0°elevation	9800	4200	2000	800	/	/	/	/	/	0°elevation

Prerequisites:

- ① Fully-extended boom + jib
- ② Outrigger span is 8.52×8.54m
- ③ 360° rotation is applied
- ④ Counterweight weight is 16.5t

Working Range(m)	49m+10.7m			49m+18m			Working Range(m)
	0°	20°	40°	0°	20°	40°	
13.72	7250						13.72
15.24	7100						15.24
16.76	6950			4550			16.76
18.29	6900	5650		4500			18.29
19.81	6700	5550	4400	4450			19.81
21.34	6550	5400	4250	4400	3640		21.34
22.86	6350	5150	4050	4380	3600		22.86
24.38	6100	4900	3900	4350	3530		24.38
25.91	5850	4650	3700	4300	3500	2480	25.91
27.43	5550	4450	3550	4250	3400	2450	27.43
28.96	5200	4250	3350	4150	3350	2430	28.96
30.48	4800	4050	3250	4050	3250	2400	30.48
32.00	4400	3700	3000	3950	3150	2350	32.00
33.53	3950	3350	2800	3750	3050	2300	33.53
35.05	3600	3050	2550	3550	2950	2250	35.05
36.58	3250	2750	2300	3300	2800	2200	36.58
38.10	2950	2500	2100	3000	2600	2100	38.10
39.62	2650	2250	1900	2750	2450	2050	39.62
41.15	2400	2050	1700	2450	2250	1900	41.15
42.67	2100	1850	1500	2200	2000	1750	42.67
44.20	1900	1650	1350	2000	1850	1600	44.20
45.72	1650	1450	1200	1800	1650	1400	45.72
47.24	1350	1250	1050	1600	1450	1250	47.24
48.77	1200	1050		1400	1300	1150	48.77
50.29	950	850		1200	1150	1000	50.29
51.82	750	650		1000	1000	850	51.82
53.34				800	850	750	53.34
54.86				600	700	600	54.86
Min. elevation angle without load	26°	28°	40°	34°	40°	40°	Min. elevation angle without load

Notes:

Warning: Lifting with the 10.7m extension base, with the 7.3m extension fly either erected or folded alongside of extension base, is strictly prohibited.

Warning: Operation of this machine with heavier loads than the capacities listed is strictly prohibited. Machine tipping with boom extension occurs rapidly and without advance warning.

1. Radii listed are for a fully extended boom with the boom extension erected. For main boom lengths less than fully extended, the rated loads are determined by boom angle. Use only the column which corresponds to the boom extension length and offset for which the machine is configured. For boom angles not shown, use the rating of the next lower boom angle.
2. Boom angle is the angle above or below horizontal of the longitudinal axis of the boom base section after lifting rated load.
3. Capacities listed are with outriggers fully extended and vertical jacks set only.
4. When lifting over extension, deduct total weight of all load handling devices reeved over main boom nose directly from extension capacity.
5. The boom extension may only be used for single line lifting service.
6. 16 parts line achieved using the additional pulley assembly (optional equipment).

SRC1200 ROUGH-TERRAIN CRANE
LOAD CHART
Prerequisites:

- ① Boom is extended from 13m to 26.2m
- ② Outrigger must be assembled (not extended)
- ③ Boom centered over front
- ④ Counterweight weight is 16.5t
- ⑤ Traveling with load at 4km/h

Working Range(m)	Boom (m)				Working Range(m)
	13.0	17.5	22.0	26.2	
3.05	32900	21750			3.05
3.66	28800	19950	25200		3.66
4.57	24200	18400	20850	18750	4.57
6.10	19650	17000	17600	16150	6.10
7.62	15900	15600	14600	13850	7.62
9.14	12600	12400	12200	11900	9.14
10.67		9950	9750	10500	10.67
12.19		7980	7800	8600	12.19
13.72		6380	6250	7000	13.72
15.24			4950	5750	15.24
16.76			3840	4650	16.76
18.29			2700	3700	18.29
19.81				2800	19.81
21.34				1750	21.34
22.86				850	22.86
No. of line	6	6	4	4	No. of line
Min. elevation angle without load	/	/	/	17°	Min. elevation angle without load
0°elevation	10000	5000	1450	/	0°elevation

Prerequisites:

- ① Boom is extended from 13m to 26.2m
- ② Outrigger must be assembled (not extended)
- ③ Boom centered over front
- ④ Counterweight weight is 16.5t
- ⑤ Keep static

Working Range(m)	Boom (m)				Working Range(m)
	13.0	17.5	22.0	26.2	
3.05	42550	42200			3.05
3.66	37450	37150	37000		3.66
4.57	31550	31300	31150	31650	4.57
6.10	24600	24350	24150	24700	6.10
7.62	19700	19400	19250	19900	7.62
9.14	16100	15850	15700	16350	9.14
10.67		13100	12900	13600	10.67
12.19		11600	11400	12750	12.19
13.72		8550	8350	9650	13.72
15.24			6050	7350	15.24
16.76			4200	5500	16.76
18.29			2700	4000	18.29
19.81				2800	19.81
21.34				1750	21.34
22.86				850	22.86
No. of line	8	8	6	6	No. of line
Min. elevation angle without load	/	/	/	17°	Min. elevation angle without load
0°elevation	14800	6150	1450	/	0°elevation

Prerequisites:

- ① **Boom is extended from 13m to 26.2m**
- ② **Outrigger must be assembled (not extended)**
- ③ **360° rotation is applied**
- ④ **Counterweight weight is 16.5t**
- ⑤ **Keep static**

Working Range(m)	Boom (m)				Working Range(m)
	13.0	17.5	22.0	26.2	
4.57	22000	21700			4.57
6.10	16150	15900	15700		6.10
7.62	12250	12000	11800	12500	7.62
9.14	9850	9450	9200	10450	9.14
10.67		6150	5900	7150	10.67
12.19		3800	3550	4800	12.19
13.72		1950	1800	3000	13.72
15.24				1600	15.24
Max. elevation angle without load	63°	72°	75°	/	Max. elevation angle without load
No. of line	4	4	3	3	No. of line
Min. elevation angle without load	/	18°	43°	48°	Min. elevation angle without load
0°elevation	6250	/	/	/	0°elevation

Notes:

1. Capacities are applicable to machines equipped with 875/65R29 radial ply tires, at 0.7Mpa cold inflation pressure.
2. Capacities appearing above the bold line are based on structural strength and tipping should not be relied upon as a capacity limitation.
3. Capacities are applicable only with machine on firm level surface.
4. On rubber lifting with boom extension not permitted.
5. Axle lockouts must be functioning when lifting on rubber.
6. For pick and carry operation, boom must be centered over front of machine, mechanical swing lock engaged and load restrained from swinging. When handling loads in the structural range with capacities close to maximum ratings, travel should be reduced to creep speeds. Especially avoid any abrupt steering, accelerating or braking.
7. All lifting depends on proper tire inflation, capacity and condition. Capacities must be reduced for lower tire inflation pressures. Damaged tires are hazardous to safe operation of crane.
8. Creep – not over 60m of movement in any 30 minute period and not exceeding 1.6km/h.
9. When making lift on rubber stationary, set parking brake.

Load Chart of Counterweight Disassembly (kg)

- ① Boom is not extended
- ② Outrigger span is 8.52×8.54m
- ③ 360°rotation is applied

Working Radius (m)	Boom 13m
3.05	23000
3.66	23000
4.57	23000
6.10	23000
7.62	23000
9.14	20000
No. of line	4

Disassembly steps:

- ① Outriggers should be fully-extended
- ② Disassembly the counterweight
- ③ Disassembly the outriggers

Assembly steps:

- ① Assembly the outriggers
- ② Outriggers should be fully-extended
- ③ Assembly the counterweight

Notes: the weight of auxiliary winch pack and counterweight is 16500kg.

Load Chart of Outrigger Disassembly (kg)

- ① Boom is not extended
- ② Tyre lifting without outrigger
- ③ Counterweight is 0t
- ④ 360°rotation is applied

Working Radius (m)	Boom 13m
3.05	7200
3.66	7200
4.57	7200
6.10	5880

When the boom is at the side of the crane without load, the elevation angle of boom shouldn't less than 41°.

When one outrigger is assembled, you can't lift load above it.

Notes: the weight of front outriggers is 4400kg and the rear is 4000kg.

Notes:

1. Values listed in the table refer to rated lifting capacity measured at flat and solid ground under the lever state of the crane.
2. Value above heavy line shall be determined by strength of the crane and under this line shall be determined by stability of the crane.
3. The working radius listed in the table is the actual radius after lifting load,
4. Rated load values determined by stability shall comply with ISO 4305.
5. Rated lifting capacity listed in the table included weights of lifting hooks (780kg of main hook and 275kg of auxiliary hook are standard configuration, one 1538kg large hook is optional) and hangers.
6. Rated lifting capacity with pulley at boom tip shall not exceed 7000kg.
7. If actual boom length and range are between two values specified in the table, larger value will determine the lifting capacity.
8. The counterweight and outriggers must be assembled when the crane is working, they could be disassembled if being transported only.
9. when assembling the counterweight and outrigger, other operations should be done after the mechanic plug is assembled while disassembling, the cylinder could be operated after the mechanic plug is disassembled.

■ TRUCK CRANE



STC200
Maximum Load Capacity: 20t
Telescopic Boom: 4 Sections, 10.6-33m



STC250
Maximum Load Capacity: 25t
Telescopic Boom: 4 Sections, 10.65-33.5m



STC250H
Maximum Load Capacity: 25t
Telescopic Boom: 5 Sections, 10.5-39.5m



STC300S
Maximum Load Capacity: 30t
Telescopic Boom: 5 Sections, 10.6-40.5m



STC300TH
Maximum Load Capacity: 30t
Telescopic Boom: 4 Sections, 10.6-33.5m



STC300H
Maximum Load Capacity: 30t
Telescopic Boom: 5 Sections, 10.5-39.5m



STC500
Maximum Load Capacity: 50t
Telescopic Boom: 5 Sections, 11.5-43m



STC550
Maximum Load Capacity: 55t
Telescopic Boom: 5 Sections, 11.5-43m



STC600S
Maximum Load Capacity: 60t
Telescopic Boom: 5 Sections, 11.3-43.5m



STC750
Maximum Load Capacity: 75t
Telescopic Boom: 5 Sections, 11.8-45m



STC800S
Maximum Load Capacity: 80t
Telescopic Boom: 5 Sections, 12.2-47m



STC1000
Maximum Load Capacity: 100t
Telescopic Boom: 5 Sections, 13.5-52m



STC1000C
Maximum Load Capacity: 100t
Telescopic Boom: 6 Sections, 13.25-60m



STC1000S
Maximum Load Capacity: 100t
Telescopic Boom: 5 Sections, 12.25-56m



STC1200S
Maximum Load Capacity: 120t
Telescopic Boom: 7 Sections, 12.6-63.5m



STC1300C
Maximum Load Capacity: 130t
Telescopic Boom: 6 Sections, 13.3-69m



STC1600
Maximum Load Capacity: 160t
Telescopic Boom: 6 Sections, 13.4-69m



STC2200
Maximum Load Capacity: 220t
Telescopic Boom: 6 Sections, 14.25-69m

■ ALL TERRAIN CRANE



SAC1800
Maximum Load Capacity: 180t
Telescopic Boom: 6 Sections, 15.5-62m



SAC2200
Maximum Load Capacity: 220t
Telescopic Boom: 6 Sections, 13.5-69m



SAC2600
Maximum Load Capacity: 260t
Telescopic Boom: 6 Sections, 15.6-73m



SAC3000
Maximum Load Capacity: 300t
Telescopic Boom: 7 Sections, 15.4-83m



SAC3500
Maximum Load Capacity: 350t
Telescopic Boom: 6 Sections, 15.2-70m



SAC6000
Maximum Load Capacity: 600t
Telescopic Boom: 7 Sections, 17.1-90m

■ ROUGH-TERRAIN CRANE



SRC250
Maximum Load Capacity: 25t
Telescopic Boom: 4 Sections, 9.9-31.5m



SRC350
Maximum Load Capacity: 35t
Telescopic Boom: 4 Sections, 10-31.5m



SRC550
Maximum Load Capacity: 55t
Telescopic Boom: 4 Sections, 11.25-34.5m



SRC660H
Maximum Load Capacity: 66t
Telescopic Boom: 5 Sections, 11.5-43m



SRC750
Maximum Load Capacity: 75t
Telescopic Boom: 5 Sections, 11.8-45m



SRC1200
Maximum Load Capacity: 120t
Telescopic Boom: 5 Sections, 13-49m

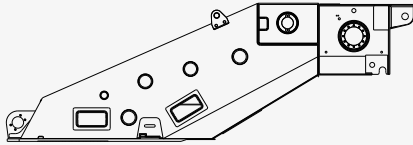

0t

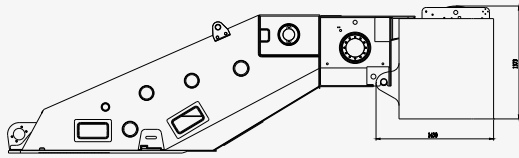

16.5t

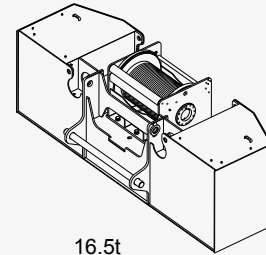
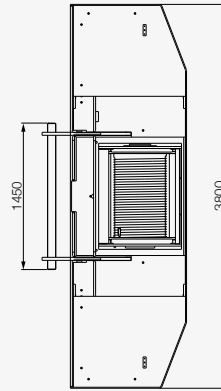
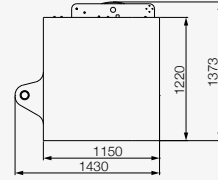
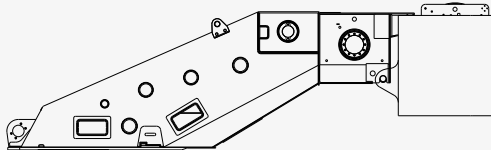
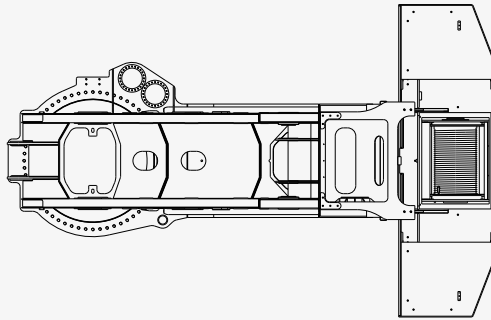

16.5t



Quality Changes the World

SANY AUTOMOBILE HOISTING MACHINERY

Address: SANY Industrial Park, Jinzhou Development Zone,
Changsha, Hunan, China.
Service Hotline: 4006098318
Email: crd@sany.com.cn
For more information, please visit: www.sanygroup.com

For our consistent improvement in technology, specifications may change without notice.
The machines illustrated may show optional equipment which can be supplied at additional cost.

Version: 2016.1

Distributed By: